

DESIGN OF THE 230 MeV PROTON ACCELERATOR FOR XI'AN PROTON APPLICATION FACILITY

S.X. Zheng, Q.Z. Xing, X.L. Guan, H.J. Yao, C. Cheng, T.B. Du, H.Y. Zhang, G.R. Li, L. Du, R. Tang, M.W. Wang, L. Wu, Y. Yang, H.J. Zeng, Q. Zhang, Z. Yang, H.P. Jiang, C.T. Du, Q.Z. Zhang, W.H. Huang, C.X. Tang, H.B. Chen, D. Wang, X.W. Wang[†], Key Laboratory of Particle & Radiation Imaging (Tsinghua University), Ministry of Education, Beijing 100084, China also at Laboratory for Advanced Radiation Sources and Application, Tsinghua University, Beijing 100084, China

also at Department of Engineering Physics, Tsinghua University, Beijing 100084, China

Z.M. Wang, C. Zhao, B.C. Wang, Y.H. Yan, Y.P. Wang, H. Zhang, M.T. Qiu, W. Chen, State Key Laboratory of Intense Pulsed Radiation Simulation and Effect (Northwest Institute of Nuclear Technology), Xi'an, 710024, China

W.Q. Guan, Y. He, J. Li, NUCTECH Co. Ltd., Beijing 100084, China

S. Y. Lee, Indiana University, Bloomington, IN 47405 USA

Abstract

We report a design of the 230 MeV proton accelerator, the Xi'an Proton Application Facility (XiPAF), which will be located in Xi'an city, China. The facility will provide proton beam with the maximum energy of 230 MeV for the research of the single event effect. The facility, composed of a 230 MeV synchrotron, a 7 MeV H⁻ linac injector and two experimental stations, will provide a flux of 10⁵~10⁸ p/cm²/s with the uniformity of better than 90% on the 10 cm×10 cm sample.

INTRODUCTION

To fulfil the need of the experimental simulation of the space radiation environment, especially the investigation of the single event effect, the project of Xi'an Proton Application Facility (XiPAF) is under construction in Xi'an City, China. The facility is mainly composed of a 230 MeV synchrotron and a 7 MeV H⁻ linac injector and two experimental stations. A proton flux of 10⁵~10⁸ p/cm²/s with the uniformity of better than 90% on the 10 cm×10 cm sample is designed. Table 1 shows the parameters of the synchrotron and linac injector.

Table 1: Main Parameters of the XiPAF

Parameter	Injector	Synchrotron
Ion type	H ⁻	Proton
Output energy (MeV)	7	60~230
Peak current (mA)	5	
Repetition rate (Hz)	0.1~0.5	0.1~0.5
Beam pulse width	10~40 μs	1~10 s
Max. average current (nA)	100	30
Flux (p/cm ² /s) (10×10cm ²)		10 ⁵ ~10 ⁸

The schematic layout of the XiPAF Accelerator system is presented in Fig. 1. The H⁻ beam is produced at the ion source (IS), accelerated to 7 MeV in linac injector, and then transferred to synchrotron through Medium Energy Beam Transport (MEBT). This H⁻ beam is stripped into

protons by carbon foil in synchrotron and it is accelerated up to 230 MeV. Then the beam is extracted to experimental station through High Energy Beam Transport (HEBT). The HEBT have two beamlines, where T2 is used for 60 to 230 MeV proton application extracted from synchrotron directly, and the T1 can degrade the proton energy from 60 MeV to 10 MeV for low energy application. The lowest extraction energy from the synchrotron is 60 MeV.

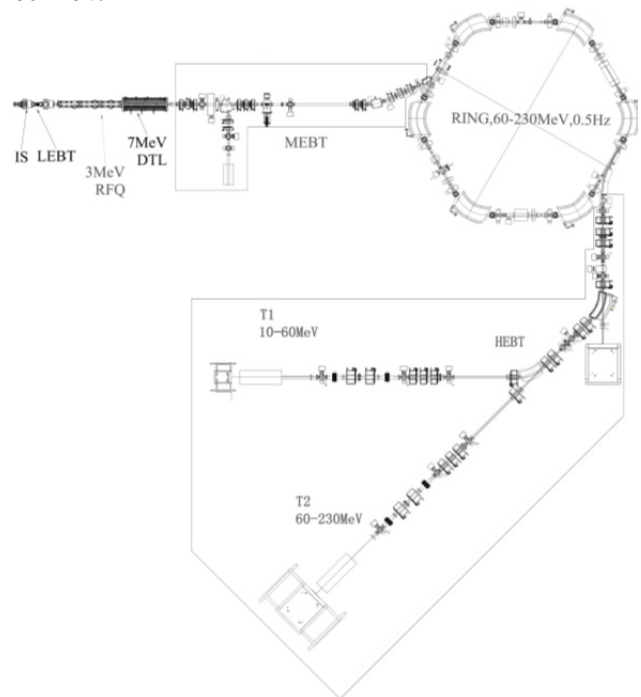

Figure 1: Layout of XiPAF accelerator system.

The main features of this accelerator are listed as follow:

- H⁻ injection enables transverse space painting flexibility in order to alleviate space charge effects at low energy.
- The 6-fold “Missing-dipole” FODO structure simplifies the lattice design and work point tuning.

[†] wangxuewu@tsinghua.edu.cn

- The magnet-alloy loaded cavity simplifies the accelerating system and provides wide beam frequency swing.
- Slow extraction with the 3rd integer resonance can provide stable, uniform and low current for proton irradiation requirement.

SYNCHROTRON

The H⁻ beam is striped into proton beam by carbon foil in injection system of synchrotron, then proton beam is adiabatically captured by RF bucket. The captured 7 MeV proton beam can be accelerated up-to 230 MeV in 0.5 second. The proton beam will be slow-extracted in 1 to 10 s.

Lattice Design

A 6-fold symmetric lattice is chosen for the synchrotron ring [1]. The basic lattice structure is called ‘missing dipole’ which is a FODO structure with one dipole is replaced by straight line. These straight line section can accommodate injection, extraction, accelerating elements. Table 2 presents the main parameters of the synchrotron lattice. The maximum magnetic field of dipole is 1.52 T at 230MeV.

Table 2: Main Parameters of the Synchrotron Lattice

Parameter	Value	Unit
Circumference	30.9	m
Dipole effective length	1.6	m
Dipole bending angle	60	degree
Dipole edge angle	30	degree
Maximum beta function(x/y)	5.7/6.0	m
Maximum dispersion	2.6	m
Tune at extraction(x/y)	1.68/1.79	
Chromaticity(x/y)	-0.2/-2.3	
Transition energy	1.64	

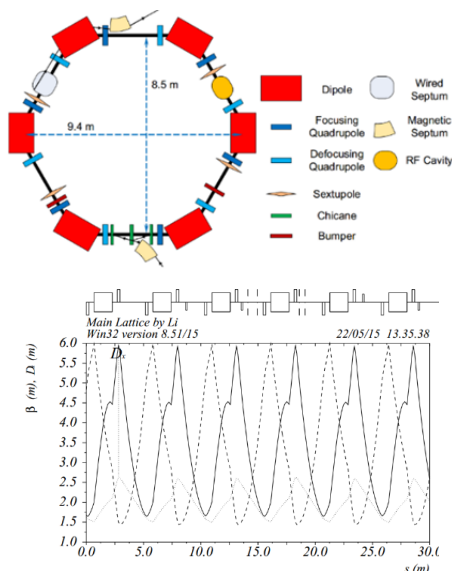

Figure 2: Layout (TOP) and twiss parameters (BOTTOM) of main ring elements.

Figure 2 shows the synchrotron layout and main parameters. The maximum beta functions are 5.9 and 6.0 meter for x and y direction separately. The base tunes are 1.68/1.79 which are chosen for the sake of 3rd integer resonated slow extraction.

Injection and Extraction System

The design intensity is 2×10^{11} proton per pulse (PPP) in synchrotron. We chose a strip injection and phase space painting method to reduce beam loss. The injection system is consisted of 3 chicane dipoles, 2 bumpers, one of injection septum magnet and one of carbon stripper. The 3 chicanes form a fixed bump closed orbit. In addition, an additional 2.4 cm bump orbit is created by 2 bumpers and restored in 30 μ s. The phase space painting process has been simulated, and the result shows the tune spread can be well controlled.

The 3rd integer resonance and RF-KO method are adopted for slow extraction. The extraction time can be varied from 1s to 10 s. The extraction elements consist of 4 sextupoles, 2 extraction magnet septum, an electrostatic wired septum and a RF-Knock-Out (RF-KO). The RF kicker signal is turned on to excite the 3rd integer resonance of circulating beam. A complicated feedback system will be used to keep extracted beam current stable. The detailed injection and extraction system design are reported in Ref [2] and [3] respectively.

Magnet Alloy Loaded Cavity

The magnet-alloy (MA) loaded broadband coaxial cavity system, shown in Fig. 3, is adopted due to its good frequency characteristics and high saturation flux density characteristics.

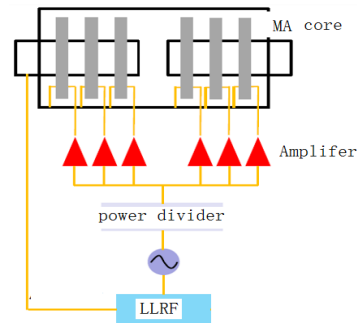

Figure 3: Layout of MA cavity system.

Table 3: Main design parameters of MA loaded cavity

Parameter	Value	Unit
Frequency	1~7	MHZ
Maximum voltage	800	V
Number of ring	6	
Impedance of ring	50	Ω
Impedance of cavity	300	Ω
Size of ring	450×300×25	
Power consume	180	W/core
Length of cavity	<630	mm
Inner D of beam pipe	120	mm

There are 6 solid state amplifiers separately coupled to 6 MA rings, each ring can induce 100 V voltage with 50 Ω impedance. This topology structure uses the cavity as an RF combiner and it simplified the system structure. Table 3 presents the main parameters of the MA loaded cavity.

7 MeV H⁻ LINAC INJECTOR

The 7 MeV linac injector [4] is composed of the 50 keV H⁻ ion source, Low Energy Beam Transport line (LEBT), 3 MeV four-vane type Radio Frequency Quadrupole (RFQ) accelerator, 4MeV (from 3 to 7MeV) Alvarez-type Drift Tube Linac (DTL), and the corresponding RF power source system. The designed number of the accumulated protons in each pulse in the synchrotron is 2×10^{11} . We choose the injection energy of 7 MeV for both achievable particle intensity and the cost of the linac injector.

ECR Ion Source and LEBT

One 2.45GHz microwave-driven Cesium-free Electron Cyclotron Resonance (ECR) ion source has been manufactured and tested successfully for XiPAF facility by Peking University. The 12.4 mA of the H⁻ beam current was measured by one Faraday cup after the analysing magnet with the RF power of 2.8 kW, beam pulse width of 1 ms, repetition rate of 100 Hz, extraction voltage of 50 kV. The measured normalized RMS emittance is 0.16 π mm mrad.

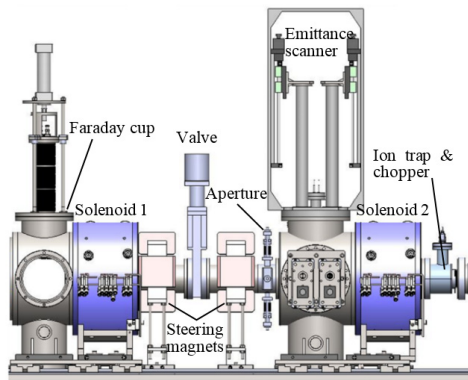

Figure 4: Layout of LEBT.

As shown in Fig.4, an adjustable aperture is exploited in the LEBT to obtain the designed current of 6 mA at the entrance of the RFQ accelerator. The matched Twiss parameters ($\alpha=1.05$, $\beta=4.94$ cm/rad) can be achieved by two solenoids. The beam pulse can be shortened to 10~40 μ s by one chopper between the solenoid-2 and the RFQ accelerator. The chopped particles will lose outside the RFQ cavity.

RFQ Accelerator

One 3-meter-long four-vane Radio Frequency Quadrupole (RFQ) will accelerate H⁻ from 50 keV to 3 MeV. The value of ρ/r_0 is kept to be 0.8 throughout the structure, where ρ is the transverse curvature of the vane tip and r_0 is the mean bore radius. The design result is shown in Fig. 5, with B is the focusing strength, X is the focusing pa-

rameter, A is the acceleration parameter, W is the synchronous energy, Φ_s is the synchronous phase, m is the modulation factor, and a is the minimum bore radius.

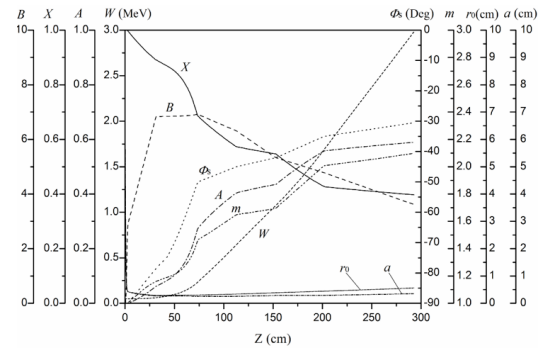

Figure 5: Parameters of RFQ vs. longitudinal position.

The length of the dipole-mode stabilizer rods is chosen to be 14.7 cm to maximize the frequency interval between the operating mode and its neighbouring dipole modes. The RF peak power of 406 kW is needed including the structure loss of 388 kW and beam power of 18 kW.

Drift Tube Linac

DTL will accelerate H⁻ from 3 MeV to 7 MeV. Samarium-cobalt permanent magnets are adopted as the transverse focusing quadrupoles for the DTL. The field gradients are designed to be constant (84.6 T/m), except that the gradients of the first four quadrupoles are adjusted to match the RFQ output beam. The total length of the DTL is about 2.2 m and the number of the accelerating cells is 23. The RF peak power of 300 kW is needed including the structure loss of 276 kW and beam power of 24 kW.

CONCLUSIONS

A 230 MeV proton accelerator had been designed for XiPAF. The facility is suitable for wide energy proton irradiation with slow extraction from 60 to 230 MeV. The project is under construction. All accelerator sub-systems including main magnets, injection elements, extraction elements and the power supplies have completed their conceptual design and the final design is in progress. The beam commissioning will be expected at the end of 2018.

ACKNOWLEDGMENT

The authors would like to thank Prof. S.X. Peng for providing the design and experimental test result of the ECR H⁻ source.

REFERENCES

- [1] G. R. Li *et al.*, “Design of the key parameters in an advanced radiation proton synchrotron”, *Modern Applied Physics*, 6, 2015.
- [2] H. J. Yao *et al.*, “H charge exchange injection for XiPAF synchrotron”, presented at HB2016, Malmö, Sweden, July 2016, paper MOPR004, this conference.
- [3] H. J. Yao *et al.*, “RF-Knockout Slow Extraction Design for XiPAF Synchrotron”, presented at HB2016, Malmö, Sweden, July 2016, paper MOPR005, this conference.

- [4] Q. Z. Xing et al., “Design of the 7MeV linac Injector for the 200MeV Synchrotron of the Xi’an Proton Application Facility”, in *Proc. IPAC’16*, Busan, Korea, May 2016, paper MOPMW014, pp. 426-428.